

THE 2MM SCALE ASSOCIATION

INSTRUCTIONS - PART - 2-326 (8'-6") & 2-327 (9')

8'-6" & 9' WHEELBASE CHASSIS FOR 1887 PLASTIC BODY WAGONS

**** READ NOTES BELOW PRIOR TO MAKING PLASTIC BODIES ****

NOTE
ALIGN HOLES FOR
BUFFERS WITH PLASTIC BODY
HOLES TO OBTAIN PLASTIC
BODY FLOOR HEIGHT

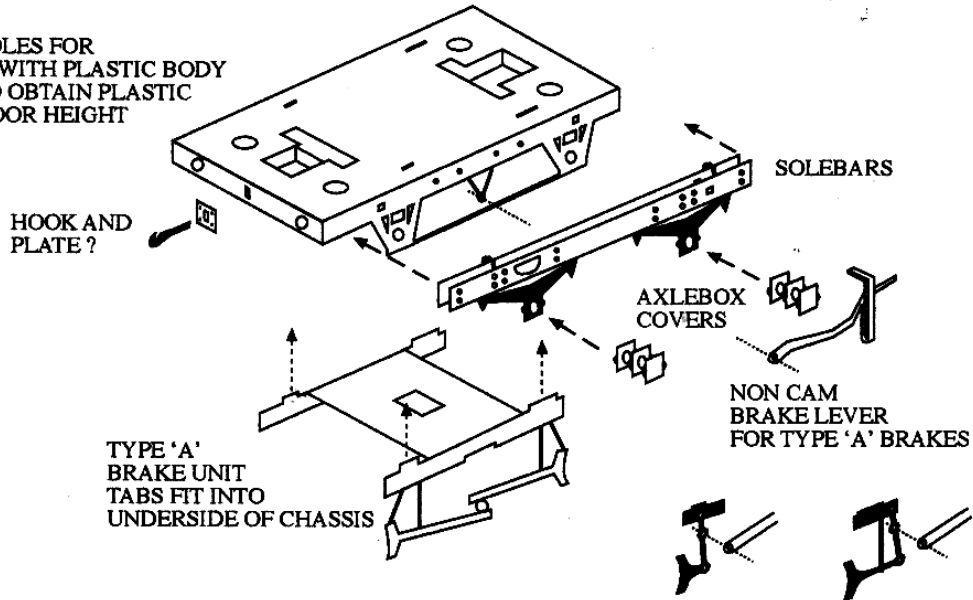

PARTS REQUIRED FROM SHOP 2 TO COMPLETE :-

2-041 TOP HAT BEARINGS 4No
2-213 6mm DIA WHEELS ON 12.25mm AXLES - 2 AXLES
2-441 BUFFERS 4 No

ALSO COUPLINGS, 0.3MM DIA WIRE FOR BRAKE RIGGING ETC.

SEE ABOVE SKETCH FOR GENERAL ARRANGEMENT OF PARTS.

CHECK AND CLEAR AS REQUIRED ALL HOLES FOR 0.3mm BRAKE RODDING ETC. CHECK SLOTS HAVE CLEARANCE FOR TABS. CLEAN OFF TAB REMNANTS.

NOTE YOUR CHOICE OF BRAKE AND LEVER (THREE DIFFERENT STYLES).

CHASSIS

FORM ENDS AND SIDES, ENSURING ALL IS SQUARE AND NOT TWISTED. USE KNOWN FLAT SURFACE SUCH AS PLATE GLASS / MDF ETC. TO WORK ON.

FORM COUPLING BOXES IF REQUIRED.

SOLDER TOP HAT BEARINGS FROM INSIDE CHASSIS INTO HALF ETCHED POCKETS.

FIT WHEELS AND CHECK FOR FREE RUNNING, THEN REMOVE FOR NOW.

SOLDER SOLEBAR OVERLAYS TOGETHER, CLEAN UP AND REMOVE 'HINGE' TABS.

SOLDER SOLEBARS TO THE CHASSIS, ALIGNING WITH TOP HATS AND TOP OF CHASSIS.

FOLD UP LAYERED AXLEBOXES AND SOLDER OR GLUE IN POSITION AFTER CLEANING UP ETC.

BRAKES

CHOOSE DESIRED BRAKE UNIT AND SOLDER IN PLACE USING LOCATION TABS/SLOTS IN CHASSIS.

****NOTE BRAKE ALTERNATIVES 'B' AND 'C' HAVE LARGE AND SMALL TABS DEPENDING ON WHICH SIDE OF CHASSIS THEY ARE TO BE FITTED TO****

MATCH BRAKE LEVER LENGTH TO CHOSEN STYLE OF BRAKE, FOLD UP LEVERS AS SHOWN ABOVE AND SOLDER IN POSITION USING 0.3MM WIRE AS RIGGING.

WASH AND CLEAN ALL SOLDERED AREAS.

RE-FIT WHEELS AND ADJUST 'W' IRONS TO GET FREE RUNNING. ENSURE BRAKE SHOES ARE NOT BINDING.

ALIGN HOLES FOR BUFFERS WITH HOLES IN PLASTIC BODY, TO OBTAIN HEIGHT FOR PLASTIC BODY FLOOR